

# CHICAGO

## Electric Power Tools

### PRESSURE WASHER 2 HP, ELECTRIC

# Model 45802

#### ASSEMBLY AND OPERATING INSTRUCTIONS



3491 Mission Oaks Blvd., Camarillo, CA 93011

Visit our Web site at <http://www.harborfreight.com>

Copyright © 2001 by Harbor Freight Tools. All rights reserved. No portion of this manual or any artwork contained herein may be reproduced in any shape or form without the express written consent of Harbor Freight Tools.

For technical questions and replacement parts, please call 1-800-444-3353

Revised Parts List and Diagram REV 09/02

## Specifications

ITEM	DESCRIPTION
Motor	2 HP
Rated Current	13A
Rated Voltage	120V
Rated Frequency	60Hz
Max. Pressure	1300 PSI
Max. Flow	1.7 GPM
GFCI Plug Cord	36' 5" L
Accessories Included	Jet Lance Wand, Foaming Lance, Hose (16' 17"), Spray Gun, Adapter (Garden Hose Thread: 3/4"-11.5 TPI, Female)
Net Weight	20.55lbs.



## Save This Manual

You will need the manual for the safety warnings and precautions, assembly instructions, operating and maintenance procedures, parts list and diagram. Keep your invoice with this manual. Write the invoice number on the inside of the front cover. Keep the manual and invoice in a safe and dry place for future reference.

## Safety Warnings and Precautions

**WARNING: When using product, basic safety precautions should always be followed to reduce the risk of personal injury and damage to equipment.**

**Read all instructions before using this product!**

1. **Keep children away from this product.** Children must never be allowed in the work area unless under close adult supervision.
2. **Know how to stop the product.** Be thoroughly familiar with all controls necessary for operation of this product before use.
3. **Stay alert.** Watch what you are doing, use common sense. Do not operate any product when you are tired.
4. **Do not operate product if under the influence of alcohol or drugs.** Read warning labels on prescriptions to determine if your judgment or reflexes are impaired while taking drugs. If there is any doubt, do not operate the product.
5. **Observe work area conditions.** Keep work area clear of all persons.
6. **Do not overreach.** Keep proper footing and balance at all times. Do not reach over or across running machines.

7. **Maintain product with care.** Follow maintenance instructions specified in this manual.
8. **Replacement parts and accessories.** When servicing, be sure to use only identical replacement parts. Use of any other parts will void the warranty. Only use accessories intended for use with this product. Approved accessories are available from Harbor Freight Tools.
9. **Do not force product.** It will do the job better and more safely at the rate for which it was intended. Do not use inappropriate attachments in an attempt to exceed the product capacity.
10. **Use the right product for the job.** Do not attempt to force a small product or attachment to do the work of a larger industrial product. There are certain applications for which this product was designed. Do not modify this product and do not use this product for a purpose for which it was not intended.
11. **Use eye and ear protection.** Always wear ANSI approved impact safety goggles.
12. **Disconnect power.** Unplug product when not in use.
13. **Avoid unintentional starting.** Be sure the switch is in the Off position when not in use and before plugging in. Do not carry any product with your finger on the trigger, whether it is plugged in or not.
14. **Check for damaged parts.** Before using any product, any part that appears damaged should be carefully checked to determine that it will operate properly and perform its intended function. Check for alignment and binding of moving parts; any broken parts or mounting fixtures; and any other condition that may affect proper operation. Any part that is damaged should be properly repaired or replaced by a qualified technician. Do not use the product if any switch does not turn On and Off properly.
15. **Guard against electric shock.** Prevent body contact with grounded surfaces such as pipes, radiators, ranges, and refrigerator enclosures.
16. **Maintenance.** For your safety, service and maintenance should be performed regularly by a qualified technician.
17. **Risk of injection or injury.** Do not aim pressure washer or its extensions directly at people or animals.
18. **Ground Fault Circuit Interrupter Protection.** This pressure washer is provided with a ground-fault circuit-interrupter (GFCI) built into the plug of the power-supply cord. This device provides additional protections from the risk of electric shock. Should replacement of the plug or cord become necessary, use only identical replacement parts that include GFCI protection.

19. **Servicing of a double-insulated appliance.** In a double-insulated product, two systems of insulation are provided instead of grounding. No grounding means is provided on a double-insulated product, nor should a means for grounding be added to the product. Servicing a double-insulated product requires extreme care and knowledge of the system, and should be done only by a qualified service personnel. Replacement parts for a double-insulated product must be identical to the parts they replace. A double-insulated product is marked with the words "DOUBLE INSULATION" or "DOUBLE INSULATED". This symbol  may also be marked on the product.
20. **Extension Cord.** Use only extension cords intended for outdoor use. These extension cords are identified with the words "ACCEPTABLE FOR USE WITH OUTDOOR APPLIANCES; STORE INDOORS WHEN NOT IN USE". Use only extension cords having an electrical rating greater than or equal to that of the product. Do not use damaged extension cords. Examine extension cord and do not yank on any cord to disconnect. Keep cord away from wet surfaces, heat and sharp edges. Always disconnect the extension cord from the receptacle before disconnecting the product from the extension cord.

**Warning:** To reduce the risk of electrocution, inspect cord before use. Do not use if cord appears damaged in any way. Keep all connections dry and off the ground. Do not touch plug with wet hands.

**Note:** Performance of this product (if powered by line voltage) may vary depending on variations in local line voltage. Extension cord usage may also affect product performance.

### General Safety Rules

1. High Pressure Hose can develop leaks from wear, kinking, abuse, etc. Water spraying from a leak is capable of injecting material into skin. Do not point the Pressure Washer spray at people or animals.
2. Locate the Pressure Washer in areas away from combustible materials, combustible fumes or dust.
3. Some chemicals or detergents may be harmful if inhaled or ingested, causing severe nausea, fainting or poisoning. These harmful elements may cause property damage or severe injury.
4. Do not allow children to operate the pressure washer at any time.
5. Before starting the Pressure Washer in cold weather, check all parts of the equipment and be sure ice has not formed anywhere on the equipment.

6. Units with broken or missing parts, or without protective housing or covers should never be used.
7. The high pressure stream of water that this equipment produces can pierce the skin and its underlying tissues, leading to serious injury and possible amputation.
8. For household use. For indoor or outdoor use. For cold tap water use.
9. Always wear eye protection when you use this equipment or when you are in the vicinity where this equipment is in use.
10. Operate the Pressure Washer at no more than the fluid pressure rated for this model.
11. Never move the machine by pulling on the High Pressure Hose. Use the handle provided on the top of the unit.
12. Use an ANSI approved respirator mask whenever there is a chance that vapors may be inhaled. Read all instructions with the mask so you are certain that the mask will provide the necessary protection against inhaling harmful vapors.
13. Keep the Hose connected to the machine and the Spray Gun while the system is pressurized. Disconnecting the Hose while the unit is pressurized is dangerous.
14. Hold the Spray Gun firmly in your hand before you start the unit. Failure to do so could result in injury from a whipping Spray Gun. Do not leave the Spray Gun unattended while the machine is running.
15. Cleaning area should have adequate slopes and drainage to reduce the possibility of a fall due to a slippery surface.
16. Keep water spray from electric wiring or fatal electric shock may result.

**Warning: The warnings, cautions, and instructions discussed in this instruction manual cannot cover all possible conditions and situations that may occur. It must be understood by the operator that common sense and caution are factors which cannot be built into this product, but must be supplied by the operator.**

## Unpacking

When unpacking, check to make sure all parts listed on Pages 12 and 14 are included. If any parts are missing or broken, please call Harbor Freight Tools at the number on the cover of this manual. In case of problems with this unit, do not use it until you have consulted an authorized service center.

## **Suitable Use of the Machine**

1. The performance and use of this machine are suitable for non-professional use. Structural technologies have been studied to assure high reliability, safe operation and long life.
2. It is absolutely forbidden to use the machine in potentially explosive environments or areas.
3. The working temperature must range between 5° and 40° C.
4. The machine consists of a motor pump protected by housing of shock resistant material. The housing shape has been studied to offer the maximum comfort of transport with suitable handle without any protrusions or dangerous corners.
5. The machine is supplied with Water Gun, equipped with a Handle to offer a practical working position; the shapes and the dimensions of the Handle correspond to the safety rules in force.
6. It is forbidden to apply any protections or modifications on the Water Gun.
7. The unit must be continuously run with cold water (at least 11-12 liters/min). Dry running will cause serious damage to the seals.
8. The cold water you use for the Washer must not be dirty, sandy or hold any corrosive chemical products, in order to protect the functionality and longevity of the equipment.
9. This machine can be used for washing rolling shutters, main doors, tiles, cars, campers, etc., where water pressure is necessary to remove dirt.
10. With attached accessories, the machine can perform foaming and washing functions with the Brush, which must be connected to the Lance.
11. Whenever you use the High Pressure Washer, we suggest to grip the Gun with one hand on the Handle and the other on the Lance.

## **Operation and Use**

Due to transport and packing dimensions reasons, some accessories may be supplied disassembled. In this case, the fitting has to be carried out as shown in the Diagram on Page 13.

All possible harmful parts of the package (plastic bag, staples, etc.) should be kept out of children's reach.

## To Attach Accessories:

1. Before using the Washer, fit the Wand [A.2] and Lance [A.3] to the Gun [A.1]: Insert the shaped tip of the Wand into the hole of the Gun, paying attention to join the notch. Press the Wand lightly towards the Gun, and rotate it in the direction of the arrows, as far as it will turn, as shown in Diagram A below.
2. Follow the same instructions to attach the Lance or the Foaming Lance [A.4] to the Gun.

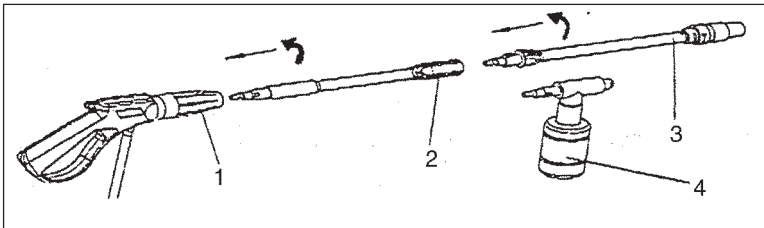

Diagram A

## To Operate:

1. Use only cold water.
2. Check the GFCI Plug and Cord before connecting the system. Plug the power cord into a grounded 120v outlet and press the reset button on the plug. **THIS MUST BE DONE EACH TIME THE UNIT IS PLUGGED INTO AN OUTLET.**

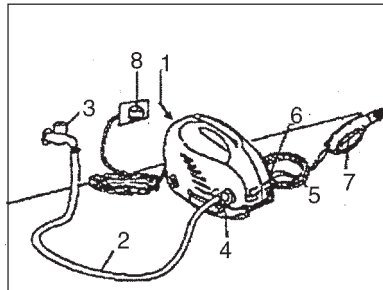

Diagram B

**Warning:** Test the GFCI Plug before each use. Plug the GFCI plug into a power outlet. The Indicator should turn red. Press the Test button. The Indicator light should disappear. Press Reset button again before use. Do not use this product if the above test fails.

3. Check to see that the O/I Switch [B.1] is in the "O" position.
4. Connect the Water Service Pipe [B.2] to the Suction Pipe Fitting Inlet [B.4] using a siphoned tube (min. 15bar/200psi) with an inside diameter of at least 13 mm (1/2").
5. Attach the Lance to the Spray Gun.
6. Connect the High-Pressure Hose [B.5] to the Delivery Pipe Outlet [B.6]. Use only cold water.

7. Open the Water Valve [B.3] completely.

8. Press the Gun Trigger [B.7] so the air and any extra pressure are expelled from the piping.
9. Connect the Plug to the Socket [B.8].
10. Start the equipment by turning the O/I Switch into the "I" position.

**Warning:** Risk of Injection: Unit will start spraying when trigger is squeezed if O/I Switch is in the "I" position. Once Switch is returned to the Off position, pressure still exists inside the unit. Therefore, be sure to point the Gun in a safe direction at all times, whether the unit is On or Off. Do not discharge stream directly at any person or animal.

Whenever you need to stop the machine, be sure to use the Safety Lock on the Gun, to avoid unintentional starting.

11. **Electric Motor:** The Electric Motor is equipped with a Thermal Switch. The Motor will stop if it overheats. If this occurs, wait 5-10 minutes before starting it again. If Motor stops again, take product to an authorized service center before attempting to start it again.
12. **Adjusting the Spraying Jet:** Turn the knob at the end of the Wand in either direction to obtain a straight or fan spray.
13. **Using Foaming Lance:** Attach Foaming Lance to the Gun as shown in Diagram C below. Turn on the Washer. Suction and mixing will occur automatically as the water flows through the Lance and the Detergent Container.

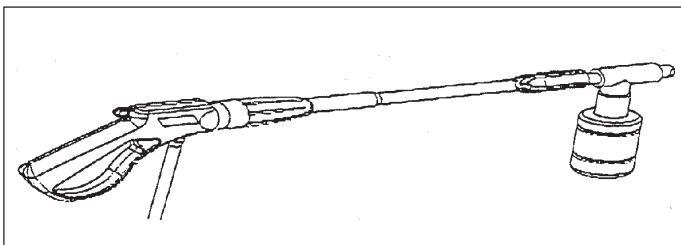

Diagram C



## **IMPORTANT BASICS REGARDING ELECTRIC PRESSURE WASHERS**

1. All connections must be tight. If there is water leaking out, air can also leak in. Make sure the water supply is fully on.
2. Check the inlet strainer for any blockage, including packaging debris. Most washers are shipped with a plastic plug in the inlet.
3. The washer will not pressurize if the nozzle is not completely assembled. It will not work properly with only part of the wand installed.
4. It may take a few warm-up tries to get the pump running correctly. Do not give up if the washer does not start immediately.
5. Minerals in the water can harden inside the workings. Flush the unit with automotive antifreeze prior to long-term storage.
6. The Foaming Lance creates foam. There is much less pressure when using the Foaming Lance.

## **Moving and Storage**

This unit is equipped with wheels, so it can be easily moved.

Store the Pressure Washer indoors. If you are keeping the machine in an environment where there is danger of ice or frost forming on the unit, or if you do not use the product for more than 3 months, we suggest you add an antifreeze solution (similar to that used in automobiles) before putting it away. When you start the machine up again, slight leakage can occur. This leakage will disappear once the machine has been in operation for a few hours.

Be careful not to damage the Electric Cable. If the Cable does become damaged, replace it with an identical replacement Cable. Only professionally qualified personnel may be allowed to replace the Electric Cable.

## **Maintenance**

Your Pressure Washer is supplied with a closed lubrication system, so you do not need to add oil. Check periodically for any deposits that might potentially clog the system.

### **PLEASE READ THE FOLLOWING CAREFULLY**

**THE MANUFACTURER AND/OR DISTRIBUTOR HAS PROVIDED THE PARTS DIAGRAM IN THIS MANUAL AS A REFERENCE TOOL ONLY. NEITHER THE MANUFACTURER NOR DISTRIBUTOR MAKES ANY REPRESENTATION OR WARRANTY OF ANY KIND TO THE BUYER THAT HE OR SHE IS QUALIFIED TO MAKE ANY REPAIRS TO THE PRODUCT OR THAT HE OR SHE IS QUALIFIED TO REPLACE ANY PARTS OF THE PRODUCT. IN FACT, THE MANUFACTURER AND/OR DISTRIBUTOR EXPRESSLY STATES THAT ALL REPAIRS AND PARTS REPLACEMENTS SHOULD BE UNDERTAKEN BY CERTIFIED AND LICENSED TECHNICIANS AND NOT BY THE BUYER. THE BUYER ASSUMES ALL RISK AND LIABILITY ARISING OUT OF HIS OR HER REPAIRS TO THE ORIGINAL PRODUCT OR REPLACEMENT PARTS THERETO, OR ARISING OUT OF HIS OR HER INSTALLATION OF REPLACEMENT PARTS THERETO.**

# Assembly Drawings and Parts Lists

Fig. 1a: Assembly Drawing for Pressure Washer, Part 1

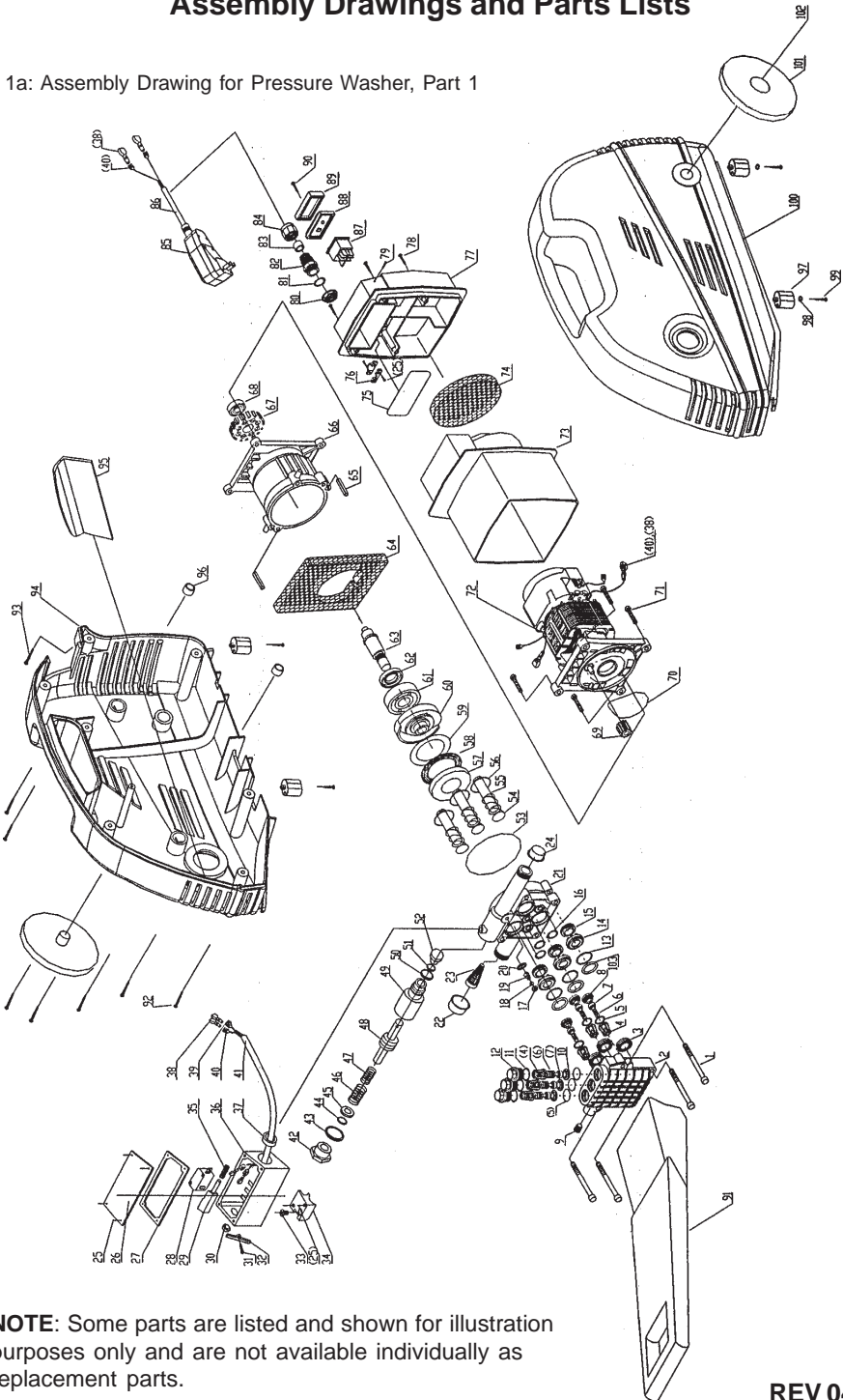

**NOTE:** Some parts are listed and shown for illustration purposes only and are not available individually as replacement parts.

REV 04/04

# Assembly Drawings and Parts Lists

Fig. 1b: Parts List for Pressure Washer

ITEM	PART NO.	DESCRIPTION	QTY
1	21000300	HEX SCREW	4
2	43002100	PUMP HEAD	1
3	26000100	SEAL,PISTON"Y"CUP	3
4	42000600	CHECK VALVE OUTLET	6
5	22000100	O-RING	6
6	43000200	SPRING	6
7	42000700	PISTON	6
8	42000800	VALVE COVER	3
9	25000200	HEX BOLT	1
10	42000900	VALVE COVER	3
11	22000300	O-RING FOR HEX BOLT	3
12	43000300	BRASS HEX BOLT	3
13	22000400	O-RING	3
14	42001000	SPACER PILOT	3
15	26000200	OIL SEAL PISTON	3
16	22000500	O-RING	3
17	42004900	O-RING	1
18	23000400	STELL BALL	1
19	43002200	TAPER SPRING	1
20	43002300	CROSS	1
21	43000400	HOUSING PISTON	1
22	42004500	COVER INLET	1
23	42000300	WATER FILTER	1
24	42000100	COVER OUTLET	1
25	21000800	SCREW	6
26	42005200	CAP	1
27	41000400	SEAL	1
28	33000300	SWITCH SPECIAL USE	1
29	42005100	POLE	1
30	41000300	TENTACLE	1
31	43002400	PIN	1
32	43002500	LEVER	1
33	21000900	SCREW	1
34	42005000	FIXED BOARD	1
35	43002600	SPRING	1
36	42005300	SWITCH BOX	1

# Assembly Drawings and Parts Lists

Fig. 1b: Parts List for Pressure Washer (continued)

37	41000500	CORD SLEEVE	1
38	37000200	SLEEVE	10
39	37000300	SLIP ON RECEPTACLE	1
40	37000100	SLIP-ON RECEPTACLE	9
41	32000100	CORD+PLUG (UL)	1
42	43002700	CAP,RETAINER	1
43	22001300	O-RING	1
44	22001400	O-RING	1
45	42005400	PLASTIC SEAL	1
46	43002800	SPRING, LONG	1
47	43002900	SPRING, SHORT	1
48	43003000	VALVE POLE	1
49	43003100	VALVE SLEEVE	1
50	22001500	O-RING	1
51	22001600	O-RING	1
52	42005500	VALVE CAP, PLASTIC	1
53	22000900	O-RING HOUSING SEAL	1
54	43000900	SPRING,PISTON RETURN	3
55	43001000	PISTON	3
56	43001100	RETAINER,PISTON SPRING	3
57	43001200	WASHER,BEARING	1
58	23000100	BEARING NEEDLE THRUST	1
59	43001300	BEARING	1
60	43001400	CAM	1
61	23000200	BEARING	1
62	22001000	SEAL	1
63	43001500	AXIS	1
64	91000100	AIR FILTER	1
65	21000400	PIN	2
66	43001900	PUMP BODY	1
67	43001600	GEAR	1
68	23000300	BEARING	1
69	43001700	GEAR	1
70	41000100	O-RING,HOUSING SEAL	1
71	21000200	SCREW	4
72	10001200	MOTOR	1
73	42005600	MOTOR CAP FOR UL	1
74	91000200	AIR FILTER	1
75	22001100	O-RING HOUSING SEAL	1
76	42004700	POWER CORD	2

# Assembly Drawings and Parts Lists

Fig. 1b: Parts List for Pressure Washer (continued)

77	42005700	BACK MOTOR COVER FOR UL	1
78	21000500	SCREW	4
79	21000700	SCREW	1
80	42001500	NUT	1
81	22001200	O-RING	1
82	42001600	SCREW	1
83	41000200	WASHER	1
84	42001700	NUT	1
85	37000500	GFCI PLUG	1
86	31000200	POWER CORD FOR UL	1
87	33000200	SWITCH	1
88	42001800	BOOT ROCKER SWITCH	1
89	42001900	ENCLOSURE ROCKER SWITCH BOOT	1
90	21000600	SCREW	1
91	42002000	HANDLE	1
92	21000100	BOLT	7
93	43002000	SCREW	1
94	42013900	HOUSING INTLET(YELLOW)	1
	42014000	HOUSING INTLET(RED)	1
	42014100	HOUSING INTLET(BLUE)	1
95	42007000	HOUSING BAFFLEF (YELLOW)FOR UL	1
	42007001	HOUSING BAFFLEF (RED)FOR UL	1
	42007002	HOUSING BAFFLEF (BLUE)FOR UL	1
96	42000400	MOUNT RUBBER	4
97	42006200	FOOT(YELLOW)	4
	42006300	FOOT(RED)	4
	42006400	FOOT(BLUE)	4
98	21001600	WASHER	4
99	21002600	SCREW	4
100	42005800	HOUSING OUTLET(YELLOW)	1
	42005900	HOUSING OUTLET(RED)	1
	42006000	HOUSING OUTLET(BLUE)	1
101	42004300	WHEEL	2
102	42004400	COVER WHEEL	2
103			3

**NOTE:** Some parts are listed and shown for illustration purposes only and are not available individually as replacement parts.

# Assembly Drawings and Parts Lists

Fig 2a: Assembly Drawing for Gun Assembly

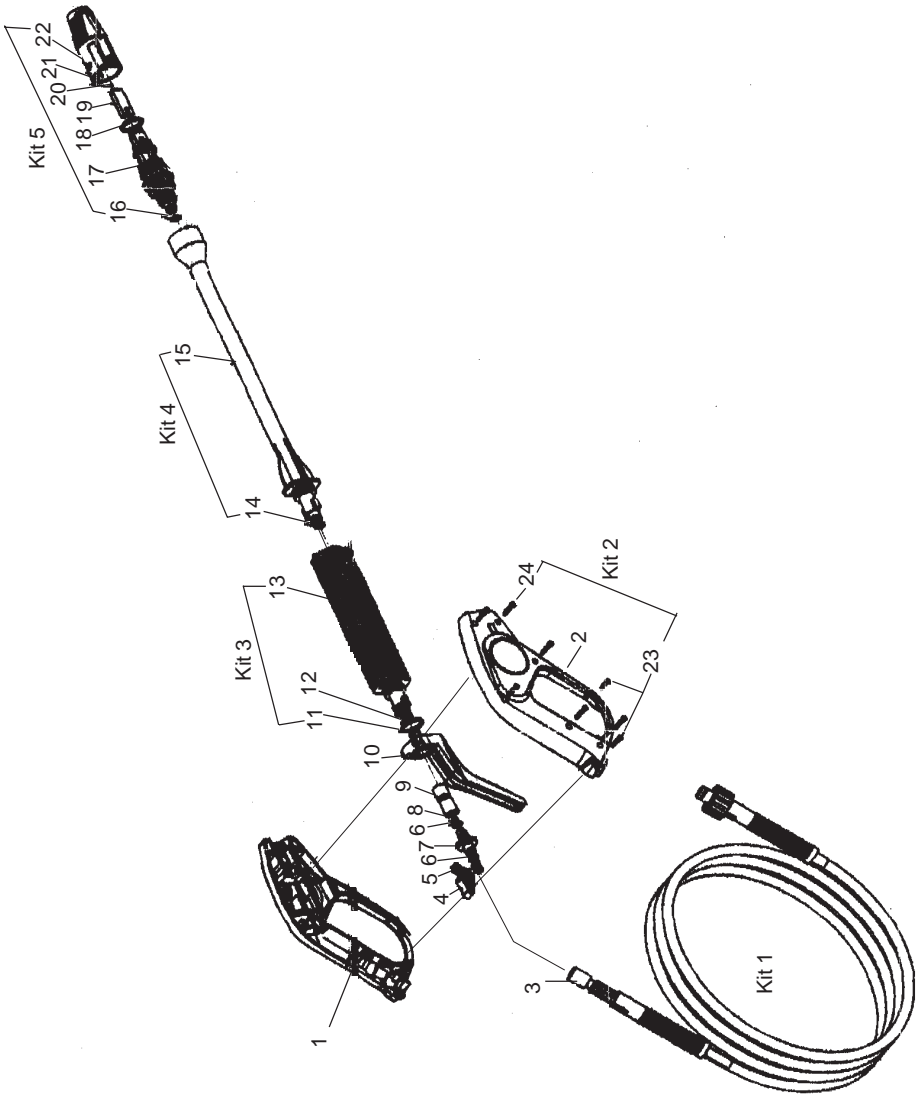

## Assembly Drawings and Parts Lists

Fig. 2b: Parts List for Gun Assembly

ITEM	DESCRIPTION	QTY
Kit 1	High Pressure Hose Assembly	1
Kit 2	Handle Assembly	1
1	Left Handle	1
2	Right Handle	1
4	Trigger Lock	1
5	Spring	1
6	Valve Big O-Ring	2
7	Valve	1
8	Valve Small O-Ring	1
9	Valve Cover	1
10	Trigger	1
23	Screw	2
24	Screw	6
Kit 3	Lance Assembly	1
11	Lance O-Ring	1
12	Lance Big O-Ring	1
13	Lance	1
Kit 4	Connecting Rod Assembly	1
14	Connecting Rod O-Ring	1
15	Connecting Rod	1
Kit 5	Nozzle Head Assembly	1
16	Nozzle Sleeve Small O-Ring	1
17	Nozzle Sleeve	1
18	Nozzle Sleeve Big O-Ring	1
19	Lamella	1
20	Nozzle	1
21	Nozzle Cover	1
22	Color Dot	1

## Trouble Shooting

FAULT	PROBABLE CAUSE	PROBABLE CAUSE
When the Switch is in the "I" position, machine will not start.	Electric Socket is faulty.	Check plug, socket, and fuses.
	The main voltage is insufficient.	Check that the main voltage is adequate.
	The pump is stuck.	Turn the motor manually.
	Total Stop Mechanism has tripped	Check the micro-switch mechanism.
When the Switch is in the "I" position, the engine buzzes, but the machine will not start.	Net Voltage (volt) is lower than the minimum suggested voltage.	Check that the electric installation is suitable.
	The pump is blocked.	Turn the motor by hand.
	Cable extension seems to be inadequate.	Replace the extension with an adequate one.
The pump doesn't reach the necessary pressure.	Water inlet filter is clogged.	Clean the water inlet filter.
	Pump is sucking air from connections or hoses.	Check that the connections and locking ring are well tightened.
	Suctions/delivery valves are clogged or worn out.	Clean or replace valves.
	Lance nozzle is incorrect or worn out.	Check and/or replace.
Fluctuating pressure.	Pump is sucking air.	Check that hoses and connections are airtight.
	Valves are dirty, worn out or stuck.	Clean or replace.
	Sealing is worn out.	Check and replace.
The motor stops suddenly.	Total Mechanism has tripped.	Check that the main voltage corresponds to the specifications. Check the micro-switch mechanism.
Water leaking from the pump.	Sealing is worn out.	Check and replace.
Loss of pressure.	The nozzle is worn out.	Replace the nozzle.
	The valves are dirty or blocked.	Check, clean or replace.
	Adjusting valve seal is worn out.	Check and/or replace.
	Seals are worn out.	Check and/or replace.
	The filter is dirty.	Check and/or clean.
Noise	Air intake.	Check the intake pipes.
	Valves are worn out, dirty or blocked.	Check, clean or replace.
	Bearings are worn out.	Check, clean or replace.
	Extreme water temperature.	Bring the temperature under 50° C.
	The filter is dirty.	Check and/or clean.
Water is in the oil.	O-Rings (water and oil) are worn out.	Check and/or replace.
Water leakage from the head.	Seals are worn out.	Replace the seals.
	O-Ring Seal System is worn out.	Replace the O-Rings.